

***Couplings FD***

***Couplings FF***

***Operating instructions***  
***spare parts list***

## 1 Introduction

---

### 1.1 Description

---

This Operation Instruction describes the exchange of gaskets and O-rings inside the flush type hydraulic couplings type FD (Main circuit) and type FF (feed circuit)

### 1.2 Qualification of operating personnel

---

The operators need to be introduced and trained for work by experienced experts.

For maintenance and repair specifically trained personnel has to be engaged. HYDROSTRESS can assist you for training.

### 1.3 Spare parts

---

Due to our efforts in the field of quality assurance the hydraulic couplings type FD and type FF represent Swiss top performance products.

Only original HYDROSTRESS spare parts assure quality and compatibility.

If proper maintenance work is neglected or done incompetently we can not fulfill the guarantee obligations set forward in our terms of delivery.

Our customer service is at your disposal to maintain your equipment in perfect condition.

We wish you trouble-free and unproblematic working with your HYDROSTRESS equipment.

HYDROSTRESS AG  
The Management

Copyright © HYDROSTRESS AG, 1998

HYDROSTRESS AG Witzbergstrasse 18 CH-8330 Pfäffikon Switzerland  Telefon 0041 (0)44 952 18 18 Telefax 0041 (0)44 952 18 00
----------------------------------------------------------------------------------------------------------------------------------------------

## 2 Table of Contents

---

<b>1</b>	<b>Introduction</b>	<b>2</b>	<b>6</b>	<b>Seal set FD 801 Coupling (female part) replacement</b>	<b>10</b>
1.1	Description	2	6.1	Tools	10
1.2	Qualification of operating personnel	2	6.2	Material	10
1.3	Spare parts	2	6.3	procedure	10
<b>2</b>	<b>Table of Contents</b>	<b>3</b>	<b>7</b>	<b>Seal set FF 372 nipple (male part) replacement</b>	<b>11</b>
<b>3</b>	<b>Tool case MKZU-WZ000-FD</b>	<b>4</b>	7.1	Tools	11
3.1	Case content tools	4	7.2	Material	11
3.2	Case content gaskets	5	7.3	Procedure	11
3.3	Cross sectional view of coupling FD	5	<b>8</b>	<b>Seal set FF 371 Coupling (female part) replacement</b>	<b>12</b>
<b>4</b>	<b>Tool case MKZU-WZ000-FF</b>	<b>6</b>	8.1	Tools	12
4.1	Case content tools	6	8.2	Material	12
4.2	Case content gaskets	7	8.3	Procedure	12
4.3	Cross sectional drawing FF-Coupling	7			
4.4	Additionally required tools	8			
<b>5</b>	<b>Seal set FD 802 nipple replacement (male part)</b>	<b>9</b>			
5.1	Tools	9			
5.2	Material	9			
5.3	Procedure	9			

### 3 Tool case MKZU-WZ000-FD

The tool case

#### **MKZU-WZ000-FD**

serves for exchanging the sealing gaskets in flush seal type hydraulic couplings type FD (main circuit).

#### 3.1 Case content tools

##### Special tools

No.	Special tool for	
7	Quadruple pin	for support of coupling while inserting the gaskets (female)
10	Plate	for support of the nipple while inserting the gasket (male)
11	Screw driver	for removal of the tappet (female)
12	Socket wrench	for loosening of the tappet nut (female)
13	Socket wrench special	three-piece
14	Double pin	for support of the nipple while inserting the gaskets (male)

15	Shaping pin	for round-shaping of the white Nylon gasket incl. O-ring after assembly (male)
17	Slip-on clamping tool	for secure clamping of coupling (male)
18	Clamping tool	for clamping of nipple in vice (male)

### 3.2 Case content gaskets

#### Gaskets for nipples (male part):

Type / Dimension	HS.-Item. No. Tyr.-Item. No.	Index on drawing
O-Ring 24x3	05O1-00240-30 979540	1
O-Ring 28.3x1.78	05O1-00283-18 979544	2
O-Ring 19x1.5	05O1-00190-15 969663	3
Nylon gasket	05R1-11406-99 979571	4

The case contains 5 sets each

#### Gaskets for coupling (female part):

Type / Dimension	HS.-Item. No. Tyr.-Item. No.	Index on drawing
O-Ring 34.65x1.78	05O1-00346-17 979545	5
Nylon gasket 22.5x18.25x 1.3	05R1-22518-95 979573	6
O-Ring 18.77x1.78	05O1-00187-17 979532	7
O-Ring 28.3x1.78	05O1-00283-18 979544	8
Tappet	07S1-00801-90 979711	9

The case contains 5 sets each

### 3.3 Cross sectional view of coupling FD

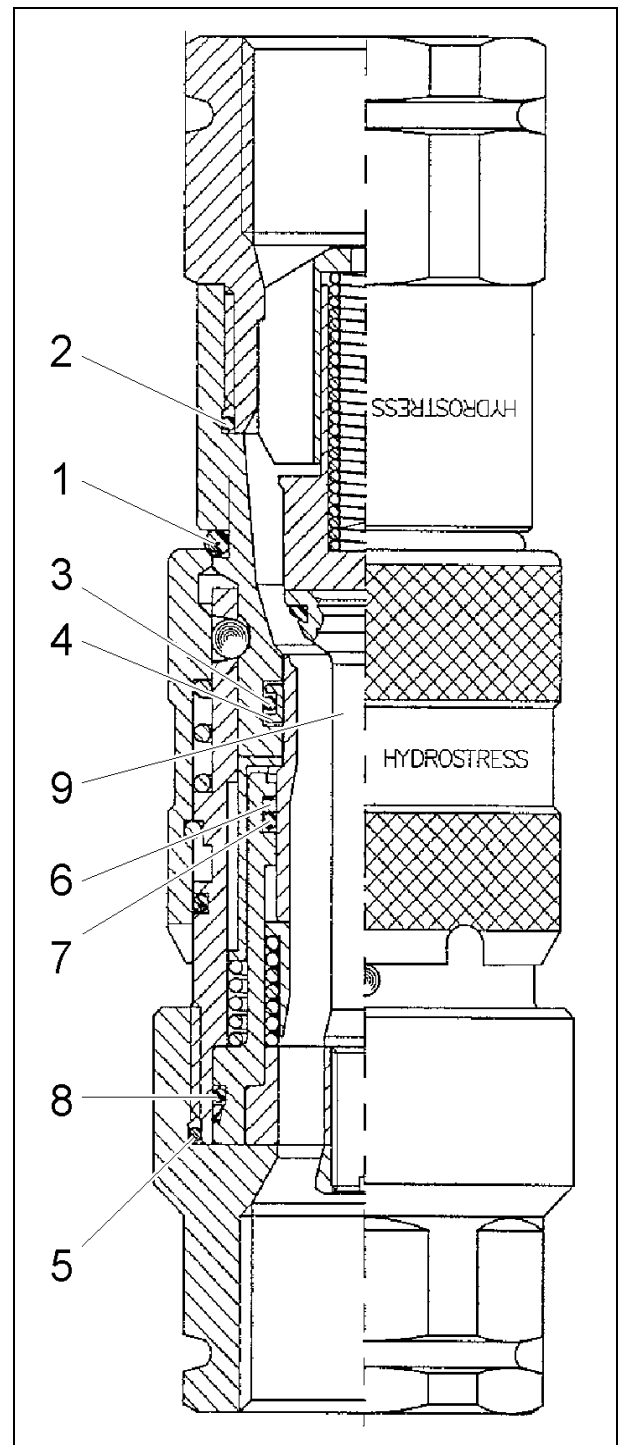

Fig. FD\_NUMER.tif

## 4 Tool case MKZU-WZ000-FF

The tool case

### **MKZU-WZ000-FF**

serves for exchanging the sealing gaskets in flush seal type hydraulic couplings type FD (feed circuit).

#### 4.1 Case content tools

##### Special tools

No.	Special tool	for
1	Pin	for support of coupling while inserting the gaskets (female)
2	Knurled bushing	for inserting and positioning of retaining ring (male)
3	Triple pin	for support of the nipple while inserting the gaskets (male)
4	Shaping pin	for round-shaping of the white Nylon gasket incl. O-ring after assembly (male)
5	Assembly tool	for insertion of safety snap ring (male)

6	Plate	for support of coupling while inserting the gaskets (female)
7	Slip-on clamping tool	for secure clamping of coupling (female)
8	Screw driver	for removal of the tappet (female)
9	Socket wrench	for loosening of the tappet nut (female)
	Puncheon	for pushing down of spring element (male)

**4.2 Case content gaskets**

*Gaskets for nipple (male part):*

Type / Dimension	HS.-Item No. Tyr. Item No.	Index on drawing
O-Ring 18.72x2.62	05O1-00187-26 979533	1
O-Ring 13x1.5	05O1-00130-15 979527	2
Nylon gasket	05R1-11406-98 979570	3

The case contains 5 sets each

*Sealing gaskets for coupling (female part):*

Type / Dimension	HS.-Item No. Tyr.-Item No.	Index on drawing
O-Ring 12.42x1.78	05O1-00120-17 979525	4
Nylon gasket 15.5x12.65x 1.4	05R1-15512-14 979572	5
Tappet	07S1-00371-90 979704	6

The case contains 5 sets each

**4.3 Cross sectional drawing  
FF-Coupling**

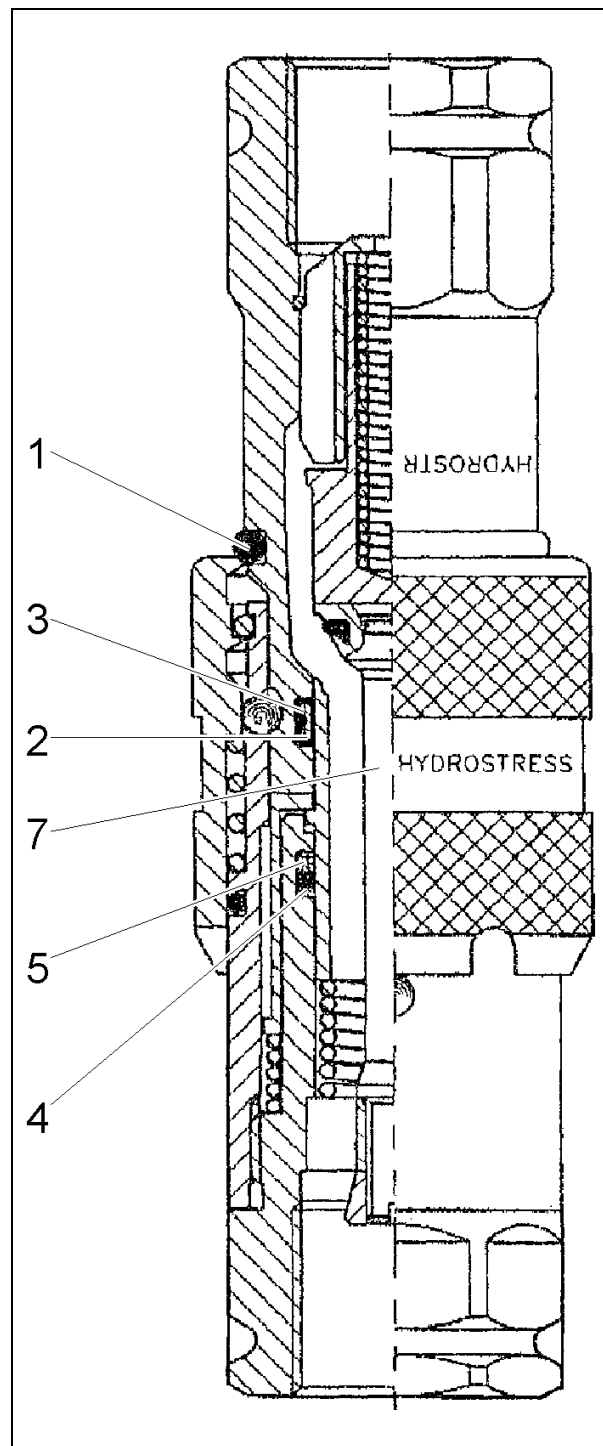

Fig. FF\_NUMER.tif

#### **4.4 Additionally required tools**

For exchange of gasket sets you need:

All tools contained in the tool cases, plus additionally:

- Vise
- Pointed pliers
- Wrench SW 24
- Wrench SW 36



## 5 Seal set FD 802 nipple replacement (male part)

### 5.1 Tools

- Special tool No. 7, 11, 15 and 18
- Wrench SW 36

### 5.2 Material

- Seal set 20D1-80200-00

### 5.3 Procedure

- Fasten nipple with help of clamping tool no. 18 in vise and open up with wrench SW 36
- Remove spring and spring fixture
- Remove frontal part of nipple from clamping tool no. 18
- Push out piston from nipple frontal part
- Clamp nipple frontal part by its smaller Ø upwards into clamping tool no. 18
- Remove white Nylon gasket (incl. O-Ring) from nipple frontal part with screwdriver no. 11
- Release nipple frontal part from clamp
- Compress white Nylon gasket **Item No. 05R1-11406-99** and O-Ring **Item No. 05O1-00190-15** in accordance with illustration and insert into groove with the help of quadruple pin no.16 and cautiously press in by screwdriver no. 11.
- Remove quadruple pin no. 16

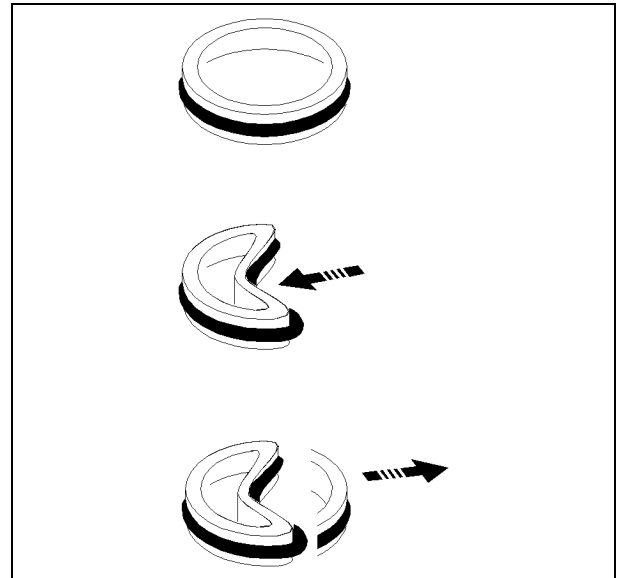

Fig. dichtung.tif

- Push shaping pin no. 15 through the white Nylon gasket thereby round-shaping the gasket
- Exchange outside O-Ring **Item No. 05O1-00240-30** and inside case
- O-Ring **Item No. 05O1-00283-18** if necessary
- Re-assemble nipple in reverse order

## 6 Seal set FD 801 Coupling (female part) replacement

### 6.1 Tools

- Special tool No.10, 11, 12, 13, 14 and 17
- Wrench SW 36

### 6.2 Material

- Seal set 20D1-80100-00

### 6.3 procedure

- Fix slip-on clamping tool no.17 in vise and slip on coupling
- Insert socket wrench no. 12 and screwdriver no. 11 into center of coupling
- Counter the tappet inside the coupling with screwdriver no. 11 and loosen and remove the nut by socket wrench no. 12
- Hold fast flow ring by socket wrench no. 13 and unscrew the tappet to the front by screwdriver no. 11
- Remove tappet
- Inspect tappet seal gasket (If defective, the complete tappet **Item No. 07S1-00801-90** must be replaced)
- Slip coupling onto slip-on clamping tool no. 17
- Open up coupling by wrench SW 36
- Remove flow ring, spring and spring sleeve
- Remove in sequence from front to rear the coupling's inner parts (3 sleeves and 1 spring) by socket wrench no. 12
- Remove white Nylon gasket and O-ring by screwdriver no. 11

- Insert O-Ring **Item No. 05O1-00187-17** by double pin no. 14
- Place plate no. 10 under the device
- Compress white Nylon gasket **Item No. 05R1-22518-95** in accordance with illustration and insert

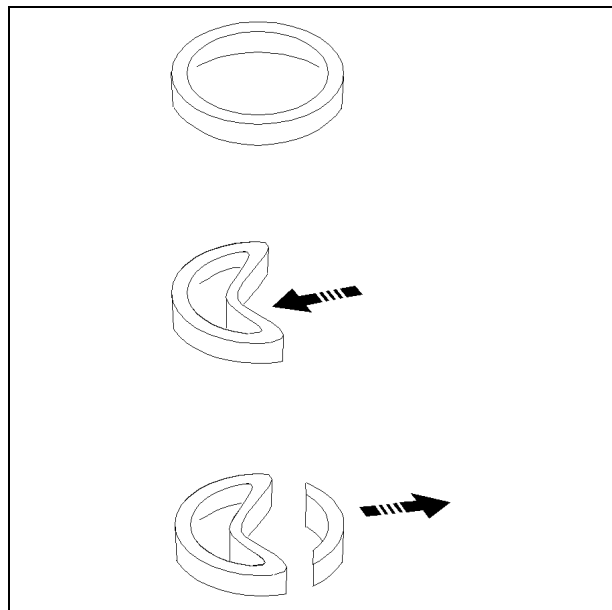

Fig. di\_oring.tif

- Use front portion of double pin no. 14 to shape gasket round
- Replace outside O-Ring **Item No. 05O1-00283-17** on inside portion of coupling
- Replace O-Ring **Item No. 05O1-00346-17** in coupling end part
- Re-assemble coupling in reverse order

## 7 Seal set FF 372 nipple (male part) replacement

### 7.1 Tools

- Special tool No. 2, 3, 4, 5 and 8
- Puncheon
- Small pointed pliers

### 7.2 Material

- Seal set 20D1-37200-00

### 7.3 Procedure

- Fasten nipple in vise
- Push down the spring element with the puncheon and cautiously extract the spring ring with the pointed pliers
- Remove spring and spring hold
- Turn nipple in vise by 180° to have smaller Ø on top
- Push piston out from nipple front part
- Remove white Nylon gasket incl. O-Ring by screwdriver no. 8
- Compress white Nylon gasket **Item No. 05R1-11406-98** and O-ring **Item No. 05O1-00130-15** in accordance with illustration and insert with the help of triple pin no. 3
- Push shaping pin no. 4 through the gasket thereby round-shaping the gasket
- Assemble piston, insert spring and spring hold
- Screw in knurled bushing No. 2
- Insert spring ring in knurled bushing
- Push retaining ring into position by assembly tool No. 5
- Verify that spring element does not rest on the slanted part of the spring ring

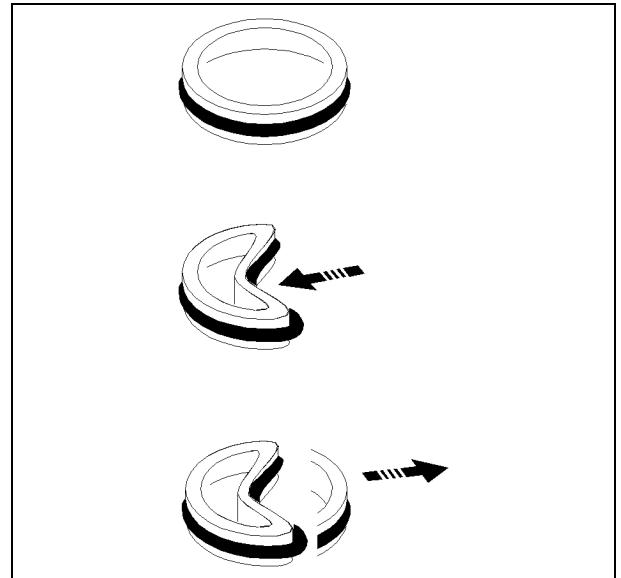

Fig. dichtung.tif

## 8 Seal set FF 371 Coupling (female part) replacement

### 8.1 Tools

- Special tool No. 1, 4, 6, 7, 8 and 9
- Wrench SW 24

### 8.2 Material

- Seal set 20D1-37100-00

### 8.3 Procedure

- Fasten slip-on clamping tool no. 7 in vise and slip on coupling
- Insert socket wrench no. 9 and screwdriver no. 8 into center of coupling
- Counter tappet inside the coupling with screwdriver no. 8 and loosen and remove nut by socket wrench no. 9
- Remove tappet by screwdriver no. 8
- Inspect tappet seal gasket (If defective, the complete tappet

**Item No. 07S1-00371-90** must be replaced)

- Loosen coupling by wrench SW 24 and disassemble coupling
- Remove white Nylon gasket incl. O-Ring by screwdriver no. 8 from the coupling rear portion
- Insert O-Ring **Item No. 05O1-00120-17** with the help of pin no. 1
- Place plate no. 6 under the device and compress and insert white Nylon seal ring **Item No. 05R1-15512-14**

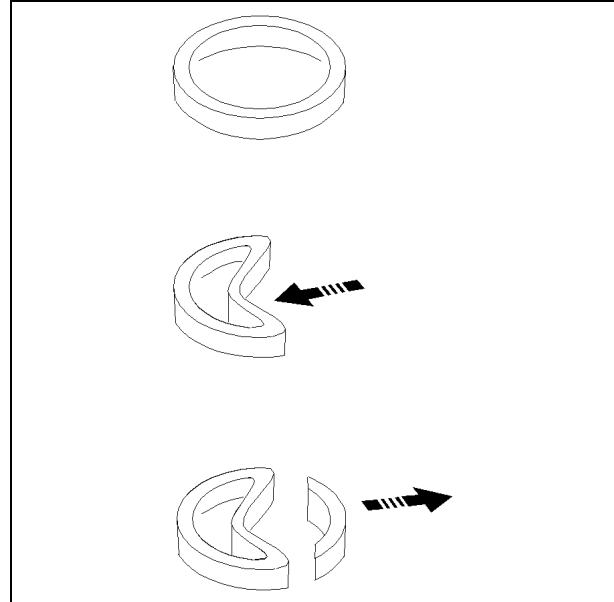

Fig. di\_oring.tif

- Push pin no. 4 through the gasket thereby round-shaping the gasket
- Re-assemble coupling in reverse order